

Square ball linear slide

HCW-CC、HCW-HC series-**HCW45HCHCW45HCHCW45HC**

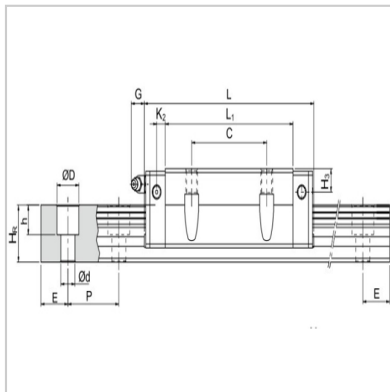
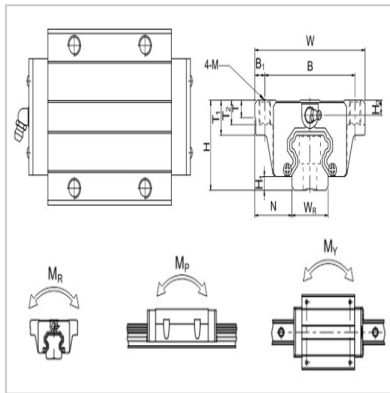

Bearing number : HCW45HC

Dimensionsof Assembly (mm) :

H :	60
H1 :	9.5
N :	37.5

Dimensions of rial (mm) :

W :	120
B :	100
B1 :	10
C :	80
L1 :	128.8
L :	171
K1 :	28.9
K2 :	10
G :	12.9
M :	M12
T :	15.1
T1 :	22
T2 :	15
H2 :	8.5
H3 :	20.5

Rail size (mm) :

Wr :	45
Hr :	38
D :	20
h :	17
d :	14
P :	105
E :	22.5

Dimensions of fastening bolts for guide rails :

(mm) :	M12x35
--------	--------

Basic rated load capacity (kN) :

C :	125.3
Co :	191.85

Allowable static moment (kN-m) :

Mr :	2.63
Mp :	2.68
My :	2.68

Weight :

Sliding block (kg) :	3.69
Guide rail (kg/m) :	10.41

: