

Square ball linear slide

HCW-CC、HCW-HC series-**HCW 20HC**HCW 20HCHCW 20HC

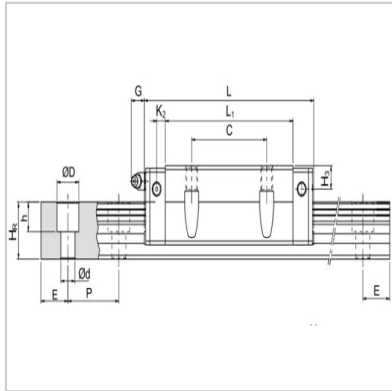
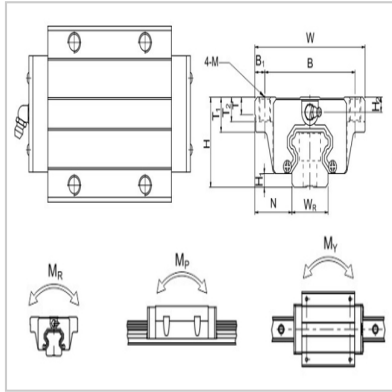

Bearing number :	HCW 20HC
------------------	----------

Dimensionsof Assembly (mm) :	
H :	30
H1 :	4.6
N :	21.5

Dimensions of rial (mm) :	
W :	63
B :	53
B1 :	5
C :	40
L1 :	65.2
L :	92
K1 :	17.6
K2 :	6
G :	12
M :	M6
T :	8
T1 :	10
T2 :	9.5
H2 :	6
H3 :	6

Rail size (mm) :	
Wr :	20
Hr :	17.5
D :	9.5
h :	8.5
d :	6
P :	60
E :	20

Dimensions of fastening bolts for guide rails :

(mm) :	M5x16
--------	-------

Basic rated load capacity (kN) :

C :	32.7
Co :	47.96

Allowable static moment (kN-m) :

Mr :	0.35
Mp :	0.35
My :	0.35

Weight :

Sliding block (kg) :	0.52
Guide rail (kg/m) :	2.21

: